

The Covalent Casting of One-Dimensional Hydrogen Bonding Motifs: Toward Oligomers and Polymers of Predefined Topography

Eric A. Archer, Adrienne E. Sochia, and Michael J. Krische*^[a]

Abstract: The covalent casting of noncovalent architectures serves to define large covalent constructs that express well-defined modes of aggregation. In the case of one-dimensional hydrogen-bonding motifs, covalent casting yields molecular strands that adopt a duplex mode of aggregation. The effectiveness of this design principle is illustrated through the casting of the aminotriazine hydrogen-bonding motif. These studies have led to the conception of a new family of topographically defined oligomers, which, akin to DNA, self-assemble in the form of a duplex through the action of interstrand hydrogen bonds.

Keywords: duplex formation • hydrogen bonds • self-assembly • template synthesis

Introduction

While factors governing the assembly of small molecules are relatively well understood, few rational approaches to the directed organization of oligomeric and polymeric precursors have been forthcoming. To simplify the task of assembling polyvalent macromolecular precursors, we have introduced the concept of “covalently casting” one-dimensional noncovalent ensembles as a general strategy toward molecular strands of *predetermined* topography, specifically a duplex mode of aggregation.^[1, 2] In this account, the covalent casting concept is reviewed. The effectiveness of this design principle is illustrated through casting of the aminotriazine H-bonding motif. The molecular strands thus derived form duplex architectures in solution and in the solid state. These studies have led to the conception of a new family of oligomers, which, akin to DNA, self-assemble in the form of a duplex through the action of interstrand H-bonds (Scheme 1).

Background

As investigations into molecular self-assembly extend to greater length scales, *macromolecular assembly* emerges as a well-defined area of research. Indeed, whereas the term “tecton” has been coined to describe noncovalent synthons of molecular dimensions,^[3] more recently, the term “foldamer”^[13a] has been introduced to describe *oligomeric* precursors for self-assembly. These efforts relate to a fundamental theme in the development of the chemical sciences: the ability to address issues of selectivity in the organization of matter across all length scales.^[4]

The paradigm for polymer assembly has advanced considerably as a consequence of recent cross-pollination between the fields of polymer and supramolecular chemistry. This is evidenced, in part, by investigations into the self-assembly of dendritic macromolecules,^[5, 6] block copolymers,^[7, 8] and the polymerization of organized assemblies.^[9, 10] These studies primarily take advantage of solvophobic driving forces to induce the formation of liquid crystalline or microphase separated domains. In contrast to solvophobic interactions, H-bond interactions are stronger and, hence, their directionality is more defined. Consequently, H-bonds have been used to generate constructs that embody more localized order, including polymers incorporating side chain H-bonding residues^[11] and H-bonded main chains.^[12] Only recently have H-bond interactions been applied toward the logic-driven retrosynthesis and assembly of synthetic oligomers that express well-defined superstructures.^[1, 2, 13]

Discussion

Covalent casting—embracing noncovalent motifs with covalent scaffolds: Covalent casting involves the superposition of covalent scaffolding upon the molecular precursors defining a noncovalent ensemble *prior* to assembly such that the covalent and noncovalent connectivities are commensurate. Covalent casting is distinguished from covalent capture,^[14] which involves the covalent fixing of a noncovalent object after its formation, thereby representing a template-directed synthesis (Scheme 2). While covalent capture may yield products that are otherwise difficult to obtain

[a] Prof. M. J. Krische, E. A. Archer, A. E. Sochia
Department of Chemistry and Biochemistry
University of Texas at Austin, Austin, TX 78712 (USA)
Fax: (+1)512 471-6835
E-mail: mkrische@mail.utexas.edu

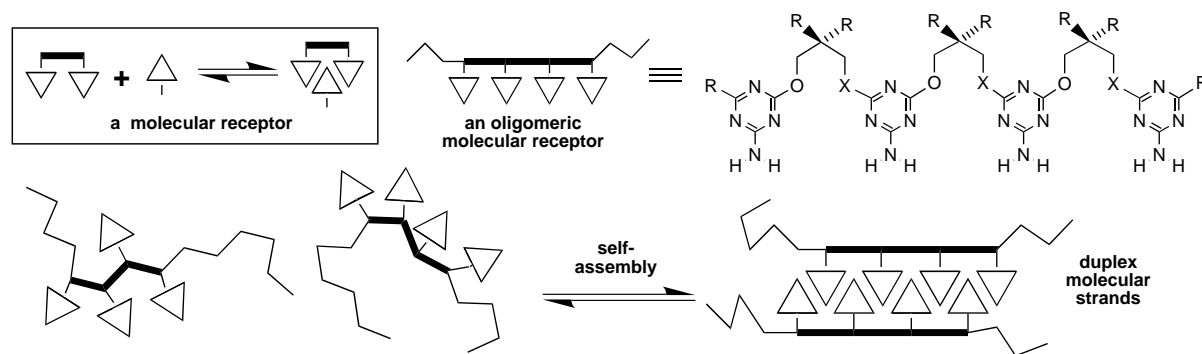

Scheme 1. Duplex-forming strands prepared through covalent casting of a one-dimensional H-bonding motif may be viewed as polymeric molecular receptors.

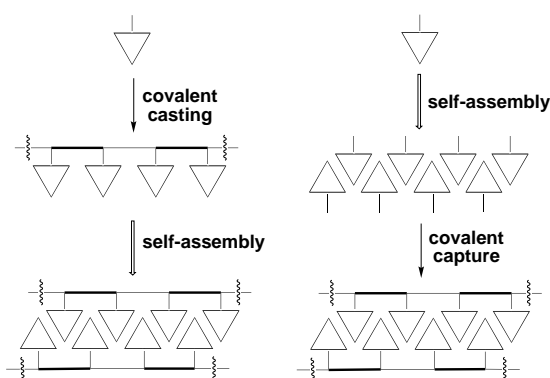

Scheme 2. Schematic depiction of the covalent casting and covalent capture of a one-dimensional construct.

(e.g. macrocycles),^[14] covalent casting does not depend upon the fidelity of assembly nor does it require that covalent fixing be conducted under conditions for which the supramolecular connectivity persists. The synergistic use of covalent casting and covalent capture strategies should represent a powerful synthetic tool for the generation of large covalent constructs of predetermined morphology.

The challenge of directing the selectivity of noncovalent binding interactions relates to the engineering of an energetic bias of sufficient magnitude so that discrimination may be achieved amongst competitive assembly manifolds.^[13b] For noncovalent interactions, the energy differences required for selection between competing modes of assembly are generally on the same order of magnitude as the very strength of the binding interactions in play. Therefore, to induce high levels of selectivity in self-assembly processes, subtle manipulation of the myriad weak forces contributing to the overall binding event is required. Preorganization represents a means of strengthening association through the reduction of entropic terms; this may be achieved by the introduction of structural features that enhance the population of binding-effective conformers. Through covalent casting, covalent frameworks are designed to embrace supramolecular frameworks, effecting preorganization of the composite noncovalent binding sites and, in turn, augmenting the stability of the noncovalent ensemble. Generally, the covalent scaffold embodies struc-

tural features that become sterically repulsive upon adoption of alternative modes of assembly, further enhancing the selectivity of aggregation. In this way, large precursors presenting multiple binding sites may be “programmed” to express preordained superstructures, which manifest high levels of structural homogeneity.

Synthetic duplex strands through covalent casting of one-dimensional H-bonding motifs:

To illustrate the utility of covalent casting as a means of managing polyvalent precursors for self-assembly, we sought to apply our design principle toward the preparation of duplex strands through the covalent casting of a one-dimensional H-bonding motif. This required 1) the selection of a one-dimensional H-bonding motif comprised of molecules amenable to further structural elaboration, and 2) the design and introduction of a covalent scaffold of dimensions commensurate with the noncovalent connectivities of the one-dimensional array.

In response to this first requirement, we recognized 2-aminopyrimidines as well established molecular precursors for the expression of one-dimensional H-bonding motifs.^[15] An identical presentation of H-bond donor–acceptor sites is found in 2-amino-4,6-dichlorotriazine (**1a**), which, as an added caveat, participates in facile chloro-substitution reactions with heteroatom nucleophiles (Scheme 3).

For the design of a covalent scaffold, the distances between adjacent triazines of the H-bonded tape must be taken into account. Specifically, since we envisioned casting to involve double chloro-substitution through the use of a bifunctional heteroatom nucleophile, the inter-chlorine distance between alternate triazines of ribbon **I** became a salient issue. This distance, about 2.5 Å, was obtained by X-ray crystallographic analysis of **1a**, which expressed the anticipated superstructure **I** in the solid state (Figure 1, top). Therefore, a bifunctional heteroatom nucleophile was required with inter-heteroatom distances matched to the inter-chlorine distances in **I**. A 1,3-diol, upon adoption of a *syn*-periplanar conformation, displays the oxygen atoms in the prescribed manner. Appreciating that the desired conformer could be favored through the Thorpe–Ingold effect, neopentyl glycols were selected as our “first generation” covalent scaffold. According to this scheme, covalent casting of the aminotriazine H-bonding motif yields

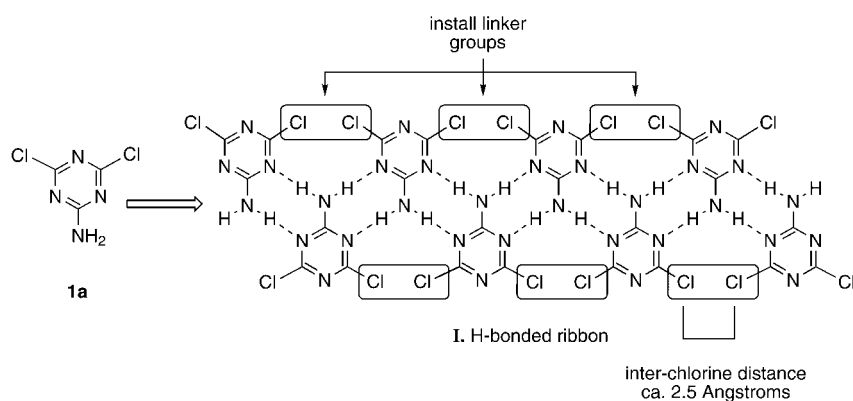

Scheme 3. Facile chloro-substitution makes 2-amino-4,6-dichlorotriazine a versatile platform for the generation of duplex strands.

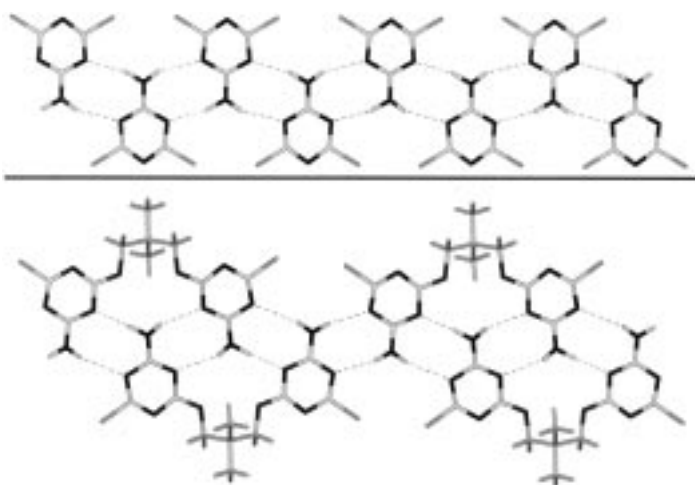

Figure 1. Top: X-ray crystal structure of **1a**, revealing the anticipated one-dimensional H-bonding motif **I**. Bottom: X-ray crystal structure of **3a** revealing the persistence of the encoded H-bonding motif upon introduction of a 1,3-diol linker and the desired duplex mode of assembly.

the diol-linked oligomers **2** ($X = O$), which express the duplex structure **II** upon self-assembly (Scheme 4).

Duplex formation in the solid-state and in solution: Having defined a distinct family of oligomers through the covalent casting concept, we sought to provide proof of principle by establishing the duplex mode of assembly. As a starting point, we first explored the simplest oligomer available, bis-amino triazine **3a** (Scheme 5), which incorporates neopentyl glycol as a linking moiety. X-ray crystallographic analysis of **3a** revealed persistence of the aminotriazine H-bonding motif upon introduction of the covalent scaffolding, thereby establishing the duplex mode of assembly and the viability of 1,3-diols as linking groups (Figure 1, bottom).

Having established the intended duplex mode of assembly in the solid state, we next endeavored to characterize the mode of assembly in solution through ^1H NMR dilution studies conducted on bis-amino triazine **4**. Dimerization of **4** occurs through the action of six H-bonds (Scheme 5). The intended duplex mode of assembly has been corroborated by X-ray crystallographic analysis of the structurally related 2,2-

dibenzyl-1,3-diol-linked species **3b**. Dilution studies performed at room temperature fit a 1:1 binding isotherm with low error, and yield the following dimerization constant in CDCl_3 : $\log K = 2.0 \pm 0.10$ ($K = 100 \text{ M}^{-1}$) (Table 1). While this value is relatively low for a complex bound by six H-bonds, it is substantially greater than that observed for the self-association of mono-triazine **1b** in CDCl_3 : ($\log K = 0.46 \pm 0.026$, $K = 2.9 \text{ M}^{-1}$) (Table 1). Nevertheless, the efficiency of dimerization for **4** may be improved

through optimization of the covalent scaffolding to further preorganize **4** in the binding-effective conformation. Specifically, adoption of the *syn*-periplanar geometry required for dimerization elicits unfavorable steric and dipole–dipole interactions in the form of eclipsed C–O bonds in the diol linker. The *nonbonded* interactions evident in **4** may, in principle, be transformed into *bonded* interactions through the utilization of an aminoalcohol linking group as in **5**, which would result in the formation of an intramolecular $\text{NH}\cdots\text{O}$ H-bond (Figure 2).

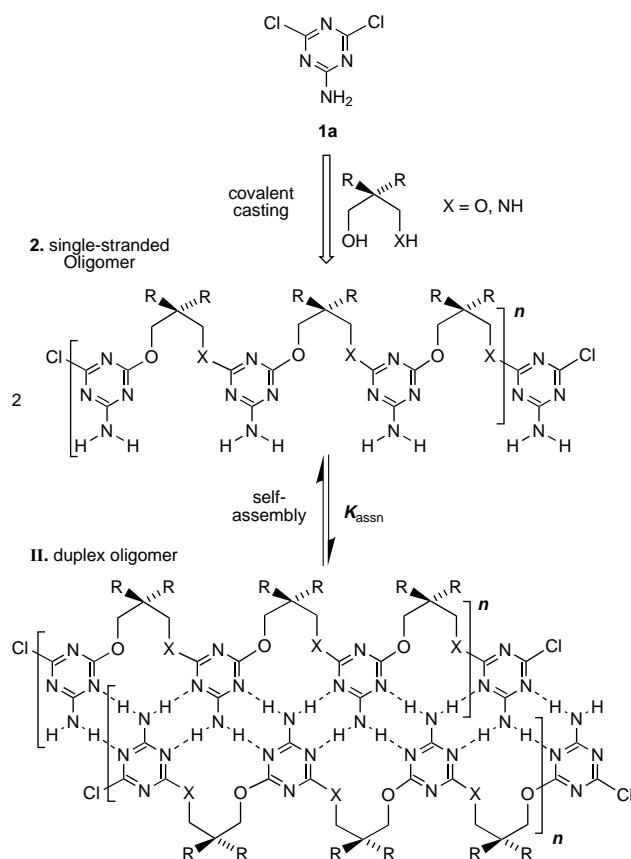

Scheme 4. Covalent casting of the aminotriazine H-bonding motif yields abiotic duplex strands.

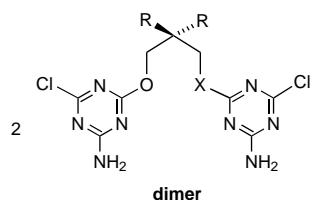

- 3a: R = CH₃, X = O
 3b: R = benzyl, X = O
 4: R = 3,5-bis(decyloxybenzyl), X = O
 5: R = 3,5-bis(decyloxybenzyl), X = NH

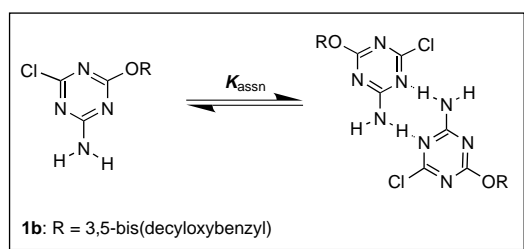
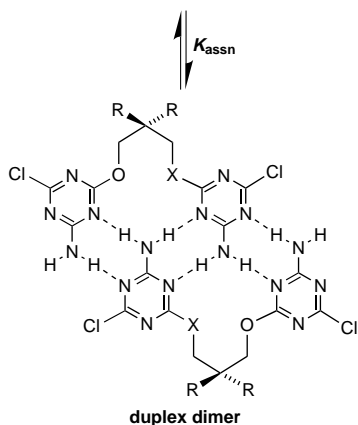

Scheme 5. Self-assembly of monomeric and dimeric aminotriazines.

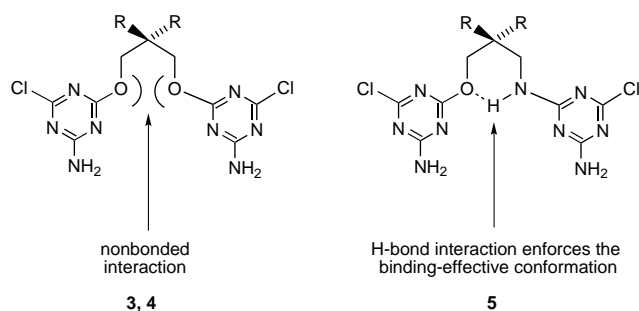

Figure 2. Optimization of the covalent scaffolding for oligotriazines through the introduction of aminoalcohol linking groups. Enhanced preorganization of **5** derives from the presence of an internal NH...O H-bond.

Indeed, the association constant pertaining to the dimerization of bis-aminotriazine **5**, which incorporates the optimized aminoalcohol-based covalent scaffold, is over *three orders of magnitude greater* than that observed for the corresponding diol-linked compound **4** in 5% [D₆]DMSO/CDCl₃ (Table 1). In fact, in neat CDCl₃, the duplex of **5** persists at the limits of ¹H NMR detection. This dramatic enhancement owes to a seemingly minor structural modifica-

Table 1. Association constants [M⁻¹] determined by ¹H NMR.^[a]

Compound	Percent [D ₆]DMSO in CDCl ₃ v:v				
	0%	1%	5%	10%	50%
1b	2.9	–	–	–	–
4	100	66	9.2	2.0	–
5	ND ^[b]	–	28000	1100	–
8b	–	–	–	ND ^[c]	1500 ^[d]
8c	–	–	–	ND ^[c]	ND ^[c]

[a] Association constants were obtained from ¹H NMR dilution data using the computer program ChemEqui developed by Dr. Vitaly Solov'ev. For a detailed description, see: V. P. Solov'ev, V. E. Baulin, N. N. Strakhova, V. P. Kazachenko, V. K. Belsky, A. A. Varnek, T. A. Volkova, G. J. Wipff, *Chem. Soc. Perkin Trans. 2* **1998**, 1489. [b] No dissociation was observed above 1.3 mM. [c] No dissociation was observed within the detection limits of the NMR experiment. [d] Results were dependent upon the amount of residual H₂O present in [D₆]DMSO. In a duplicate experiment using dry DMSO, dissociation was not observed.

tion: the substitution of nitrogen for oxygen in the linking moiety.

For the preparation of higher oligomers, we have devised an homologation protocol allowing sequential extension of oligo-aminotriazines to yield monodisperse dimeric, trimeric, and tetrameric strands **8a–c** (Scheme 6). As evidenced by binding constants obtained for the series of oligomers in increasingly competitive media, interstrand affinity improves with increasing strand length. The low errors obtained upon fitting the data to a 1:1 binding model, along with the relative magnitude of the binding constants as a function of medium, strongly supports “in register” duplex formation. We are currently analyzing dye-labeled strands in order to determine binding constants in noncompetitive media by fluorescence resonance energy transfer (FRET) techniques.

Having prepared discrete duplex oligomers, the preparation of polymeric materials was desired. Diol-linked aminotriazine dimer **9** undergoes condensation polymerization with homopiperazine, which may be viewed as a conformationally constrained 1,3-diamine.^[1a] The polymer backbone contains alternating 1,3-diol and 1,3-diamine linkages. More recently, we have begun to explore the polymerization of the “second generation” aminoalcohol-linked derivatives. The aminoalcohol-linked polymers **10b** should be obtained by self-condensation of **6** upon unmasking of the latent Boc-protected amine nucleophile (Scheme 7).

Characterization of the topography of polymers **10** is currently underway. However, a qualitative indication that **10a** adopts a compact globular structure as a result of the formation of intramolecular H-bonds is provided by temperature dependent GPC analysis. Specifically, large increases (20–24%) in apparent molecular weight are observed upon modest increases in temperature (Table 2). Notably these studies were performed in THF solvent, a competitive medium for H-bond formation.

The covalent casting of alternative one-dimensional H-bonding motifs: Covalent casting of the aminotriazine H-bonding motif has led to a new family of covalent-noncovalent ladder

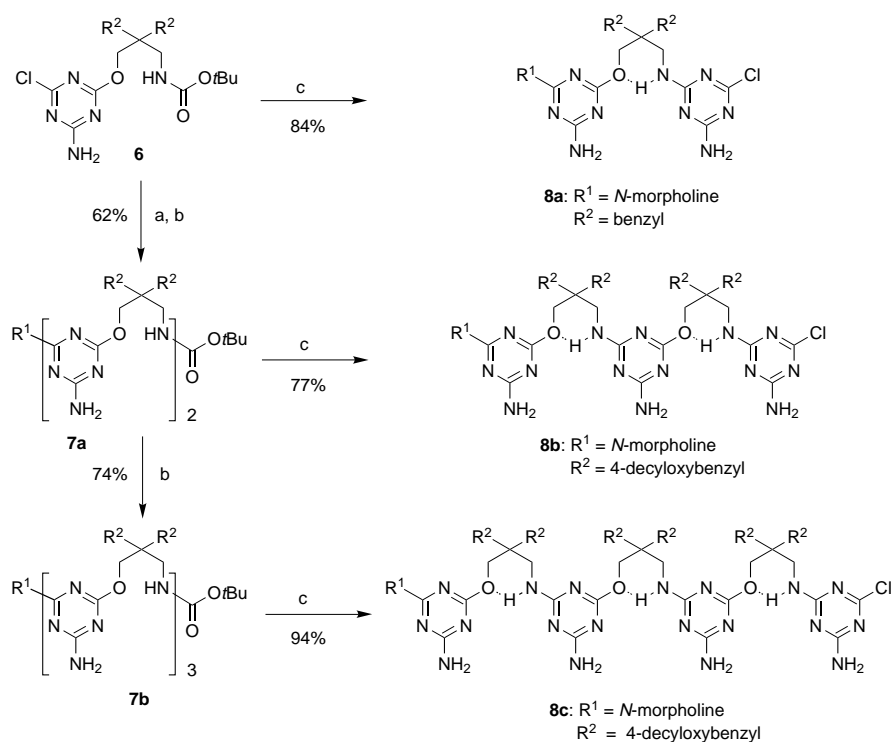

Scheme 6. Synthesis of homologous oligotriazines **8a–c**. a) Morpholine (2 equiv), CHCl₃, reflux. b) HCl, dioxane/CH₂Cl₂, 25 °C, then **6**, CHCl₃, *i*PrNEt₂, reflux. c) HCl, dioxane/CH₂Cl₂, 25 °C, then **1a**.

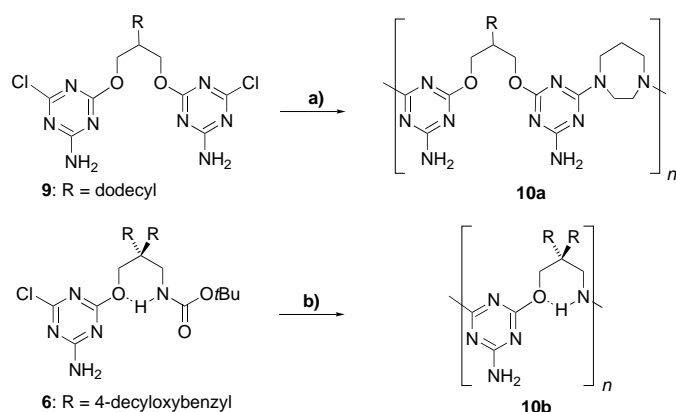

Scheme 7. Preparation of polymers **10a** and **10b**. a) DMSO, *i*PrNEt₂, homopiperazine, 50 °C. b) HCl, dioxane/CH₂Cl₂, then CHCl₃, *i*PrNEt₂, reflux.

Table 2. Peak molecular weight of **10a** measured by GPC^[a] as a function of concentration and temperature.^[b]

Entry	Sample conc. [mg mL ⁻¹] ^[c]	M.p. (25 °C)	M.p. (50 °C)
1	4.0	37 100	46 000
2	1.0	35 500	42 600

[a] Gel permeation chromatography in THF, calibrated with polystyrene standards at both temperatures. [b] Column temperature maintained by heated enclosure. [c] Injection volume = 100 μL.

materials. In principle, a diverse range of duplex materials possessing programmable self-association characteristics may be obtained through the covalent casting of selected H-bond-

ing motifs. To illustrate the generality of the covalent casting design principle, studies on the casting of alternative one-dimensional H-bonding motifs have been initiated. 1,4-Diaminophthalazine (**11**) was anticipated to express a one-dimensional superstructure (Figure 3, top). The H-bonding motif of **11** and related structures (e.g. 1,4-diaminopyridazine) are yet unknown in the literature. For this reason single crystals of **11** were grown and analyzed by X-ray diffraction. The anticipated H-bonding motif was observed in the solid-state (Figure 3, bottom).

Studying interatomic distances obtained from the crystal structure of **11** facilitates the design of a covalent scaffold. A *trans*-1,4-but-2-ene diol linkage, as shown for dimeric 1,4-diaminophthalazine **12**, is roughly commensurate with the supramolecular connectivities revealed in the crystal structure. Studies related to the assembly **12** in solution and in the solid state are currently underway (Scheme 8).

Thus far, we have described systems that self-associate, that is, the self-assembly of homomeric strands. The melamine–cyanuric acid H-bonding motif^[16] provides an opportunity to

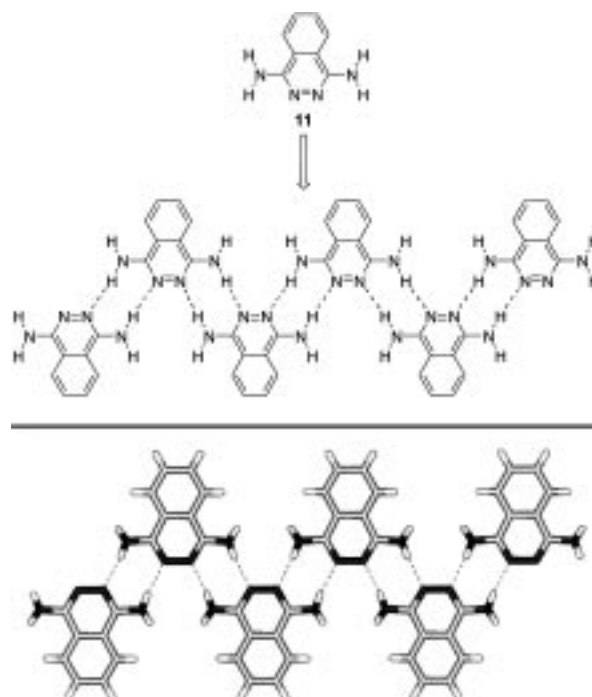
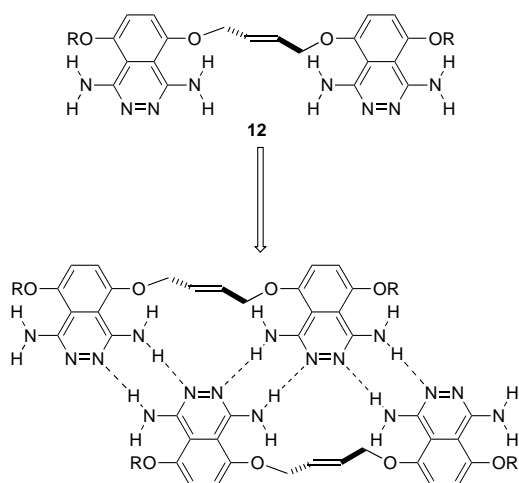

Figure 3. Top: 1,4-Diaminophthalazine (**11**) and anticipated one-dimensional H-bonding motif. Bottom: X-ray crystal structure of **11** revealing the anticipated mode of assembly.



Scheme 8. An alternative duplex assembled from proposed diamino-phthalazine dimer **12**.

cast heteromeric duplex materials. The isophthaloyl moiety serves as a covalent scaffold for the melamine portion of the H-bonded tape. The cyanuric acid-containing strand is cast by the introduction of a semi-rigid polyamide backbone (Scheme 9).

The conjugation of different ADP oligomers raises numerous possibilities involving the design of self-replicating sys-

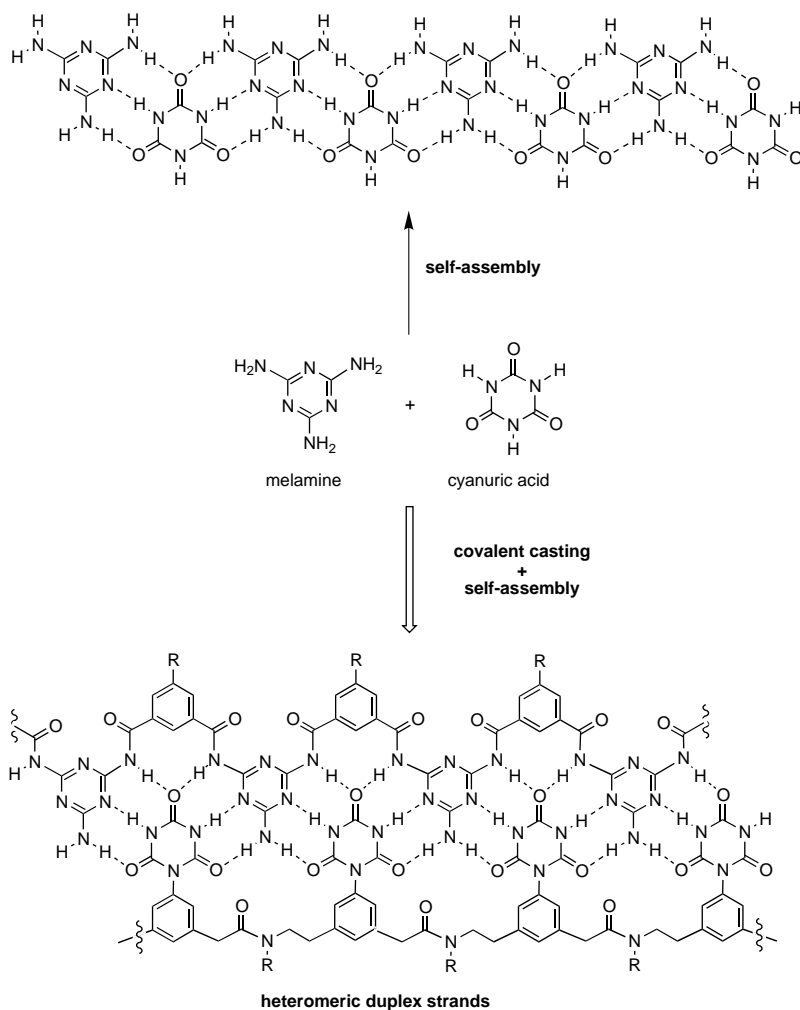

Scheme 9. Covalent casting of the melamine-cyanuric acid H-bonded tape to yield heteromeric duplex strands.

tems.^[17] Each unique oligomer may serve a multi-site receptor for its composite monomers. As such, a strand may template its own formation by preorganization of the monomers along the polymer in a manner geometrically suited for introduction of covalent scaffolding. Covalent capture of the templated monomers would result in the formation of a duplicate strand. The outcome of templated versus untemplated polymerization is most easily assessed in block polymer systems incorporating different H-bonding recognition motifs as depicted schematically (Scheme 10). Self-replication in

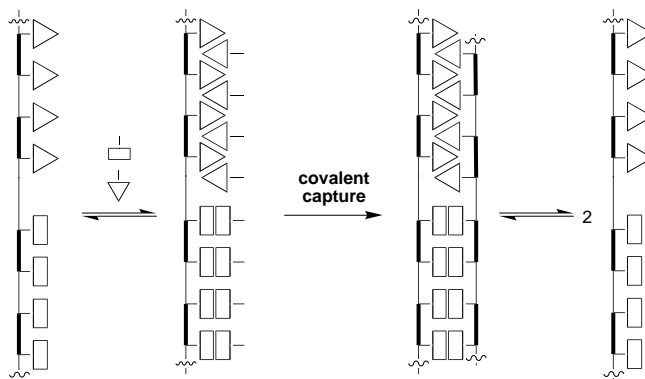

Scheme 10. Self-replication of a block-oligomer ADP represents an abiotic version of the PCR process.

this manner would be equivalent to an abiotic version of the polymerase chain reaction (PCR).

Perspectives: In Nature, nanostructured objects are assembled from macromolecular precursors. Biomacromolecules, such as proteins and DNA, not only exhibit high levels of structural homogeneity, but possess exceptional mechanical properties (e.g. arachnid silk fibers)^[18], selective catalytic functions (e.g. cytochrome-p450)^[19], and information storage capabilities (DNA/RNA).^[20] By developing technologies for the controlled induction of superstructure in oligomeric and polymeric precursors through self-assembly, steps are taken toward the definition of a platform for the de novo design of synthetic polymer-based devices of nanometric dimensions, which, upon sufficient development, may embody capabilities beyond those displayed by their natural counterparts.

The covalent casting of non-covalent ensembles has been

introduced as a design strategy for the preparation of large covalent constructs of *predefined* superstructure. Strategies for the spontaneous yet controlled assembly of polymeric precursors will permit the generation of nanostructured supramolecular materials that bridge molecular and lithographic size regimes.^[21] It is the authors' hope that this account will stimulate further studies toward the design of polymer-based architectures en route to functional materials.

Acknowledgements

For partial support of this research, acknowledgment is made to the donors of the Petroleum Research Fund administered by the ACS and the Center for Nanostructured Materials at the University of Texas at Austin. Dr. Vitaly Solov'ev is thanked for use of the program ChemEqui.

- [1] a) E. A. Archer, N. T. Goldberg, V. Lynch, M. J. Krische, *J. Am. Chem. Soc.* **2000**, *122*, 5006–5007; b) E. A. Archer, D. F. Cauble Jr., V. Lynch, M. J. Krische, unpublished results.
- [2] For alternative approaches to duplex oligomers, see: a) A. P. Bisson, F. J. Carver, D. S. Eggleston, R. C. Haltiwanger, C. A. Hunter, D. L. Livingstone, J. F. McCabe, C. Rotger, A. E. Rowan, *J. Am. Chem. Soc.* **2000**, *122*, 8856–8868; b) P. S. Corbin, S. C. Zimmerman, *J. Am. Chem. Soc.* **2000**, *122*, 3779–3780; c) H. Zeng, R. S. Miller, R. A. Flowers II, B. Gong, *J. Am. Chem. Soc.* **2000**, *122*, 2635–2644; d) V. B. Berl, I. Huc, R. G. Khoury, M. J. Krische, J.-M. Lehn, *Nature* **2000**, *407*, 720–723.
- [3] X. Wang, M. Simard, J. D. Wuest, *J. Am. Chem. Soc.* **1994**, *116*, 12119–12120.
- [4] For selected reviews, see: a) G. A. Ozin, *Chem. Commun.* **2000**, 419–432; b) A. P. Alivisatos, P. F. Barbara, A. W. Castleman, J. Chang, D. A. Dixon, M. L. Klein, G. L. McLendon, J. S. Miller, M. A. Ratner, P. J. Rossky, S. I. Stupp, M. E. Thompson, *Adv. Mater.* **1998**, *10*, 1297–1336.
- [5] For reviews, see: a) H. Frey, *Angew. Chem.* **1998**, *110*, 2313–2318; *Angew. Chem. Int. Ed.* **1998**, *37*, 2193–2197; b) J. M. J. Fréchet, *Science* **1994**, *263*, 1710–1715.
- [6] For selected examples, see: a) S. C. Zimmerman, F. Zeng, D. E. C. Reichert, S. V. Kolotuchin, *Science* **1996**, *271*, 1095–1098; b) V. Percec, W.-D. Cho, P. E. Mosier, G. Ungar, D. J. P. Yearley, *J. Am. Chem. Soc.* **1998**, *120*, 11061–11070; c) S. D. Hudson, H.-T. Jung, V. Percec, W.-D. Cho, G. Johansson, G. Ungar, V. S. K. Balagurusamy, *Science* **1997**, *278*, 449–452; d) J. Barera, M. Marcos, J. L. Serrano, *Chem. Eur. J.* **1999**, *5*, 1834–1840; e) W. Stocker, B. L. Schürmann, J. P. Rabe, S. Förster, P. Lindner, I. Neubert, A.-D. Schlüter, *Adv. Mater.* **1998**, *10*, 793–797.
- [7] For a review, see: E. L. Thomas, *Science* **1999**, *286*, 1307–1307.
- [8] For selected examples, see: a) V. Percec, C.-H. Ahn, G. Ungar, D. J. P. Yearley, M. Moller, S. S. Sheiko, *Nature* **1998**, *391*, 161–164; b) S. I. Stupp, V. LeBonheur, K. Walker, L. S. Li, K. E. Huggins, M. Keser, A. Amstutz, *Science* **1997**, *276*, 384–389.
- [9] For a review, see: D. F. O'Brian, B. Armitage, A. Benedicto, D. E. Bennet, H. G. Lamparski, Y.-S. Lee, W. Srisiri, T. M. Sisson, *Acc. Chem. Res.* **1998**, *31*, 861–868.
- [10] For selected examples, see: a) E. R. Zubarov, M. U. Pralle, L. Li, S. I. Stupp, *Science* **1999**, *283*, 523–526; b) D. H. Gray, D. L. Gin, *Chem. Mater.* **1998**, *10*, 1827–1832; c) M. de Loos, J. van Esch, I. Stokroos, R. M. Kellogg, B. L. Feringa, *J. Am. Chem. Soc.* **1997**, *119*, 12675–12676; d) J. Chen, W. Cao, *Chem. Commun.* **1999**, 1711–1712.
- [11] For selected examples, see: a) B. D. Edgecombe, J. M. J. Fréchet *Chem. Mater.* **1998**, *10*, 994–1002; b) B. D. Edgecombe, J. A. Stein, J. M. J. Fréchet, Z. Xu, E. J. Kramer, *Macromolecules* **1998**, *31*, 1292–1304; c) T. Kato, H. Kihara, S. Ujiie, T. Uryu, J. M. J. Fréchet, *Macromolecules* **1996**, *29*, 8734–8739; d) R. F. M. Lange, E. W. Meijer, *Macromol. Symp.* **1996**, *102*, 301–308; e) T. Kato, H. Kihara, T. Uryu, A. Fujishima, J. M. J. Fréchet, *Macromolecules* **1992**, *25*, 6836–6841; f) T. Kato, N. Hirota, A. Fujishima, J. M. J. Fréchet, *J. Polym. Sci. Polym. Chem. Ed.* **1996**, *34*, 57–62.
- [12] For selected reviews, see: a) R. F. M. Lange, M. Van Gurp, E. W. Meijer, *J. Polym. Sci. Polym. Chem. Ed.* **1999**, *37*, 3657–3670; b) J. S. Moore *Curr. Opin. Colloid Interf. Sci.* **1999**, *4*, 108–116; c) N. Zimmerman, J. S. Moore, S. C. Zimmermann, *Chem. Ind.* **1998**, 604–610; d) R. P. Sijbesma, E. W. Meijer, *Curr. Opin. Colloid Interf. Sci.* **1999**, *4*, 24–32; e) C. T. Imrie, *Trends Polym. Sci.* **1995**, *3*, 22–29; f) C. Alexander, C. P. Jariwala, C.-M. Lee, A. C. Griffin, *Macromol. Chem. Macromol. Symp.* **1994**, *77*, 283–294.
- [13] a) S. H. Gellman, *Acc. Chem. Res.* **1998**, *31*, 173–180; b) E. A. Archer, H. Gong, M. J. Krische, *Tetrahedron* **2001**, *57*, 1139–1159.
- [14] For selected examples, see: a) F. Cardullo, M. C. Calama, B. H. M. Snellink-Ruël, J.-L. Weidmann, A. Bielejewska, R. Fokkens, N. M. M. Nibbering, P. Timmerman, D. N. Reinhoudt, *Chem. Commun.* **2000**, 367–368; b) T. D. Clark, M. R. Ghadiri, *J. Am. Chem. Soc.* **1995**, *117*, 12364–12365; c) H. E. Blackwell, R. H. Grubbs, *Angew. Chem.* **1998**, *110*, 3469–3472; *Angew. Chem. Int. Ed.* **1998**, *37*, 3281–3284; d) B. Mohr, M. Weck, J.-P. Sauvage, R. H. Grubbs, *Angew. Chem.* **1997**, *109*, 1365–1367; *Angew. Chem. Int. Ed. Engl.* **1997**, *36*, 1308–1310; e) M. J. Marsella, H. D. Maynard, R. H. Grubbs, *Angew. Chem.* **1997**, *109*, 1147–1150; *Angew. Chem. Int. Ed. Engl.* **1997**, *36*, 1101–1103.
- [15] M. J. Krische, J.-M. Lehn, N. Kyritsakas, J. Fischer, E. Wegelius, K. Rissanen, *Tetrahedron* **2000**, *56*, 6701–6706.
- [16] a) J.-M. Lehn, M. Mascal, A. DeCian, J. Fischer, *Chem. Commun.* **1990**, 479–481; b) J. A. Zerkowski, C. T. Seto, D. A. Wierda, G. M. Whitesides, *J. Am. Chem. Soc.* **1990**, *112*, 9025–9026.
- [17] A. Robertson, A. J. Sinclair, D. Philp, *Chem. Soc. Rev.* **2000**, *29*, 141–152.
- [18] Y. Qu, S. C. Payne, R. P. Apkarian, V. P. Conticello, *J. Am. Chem. Soc.* **2000**, *122*, 5014–5015.
- [19] For a review, see: G. H. Loew, D. L. Harris, *Chem. Rev.* **2000**, *100*, 407–419 and references therein.
- [20] a) L. M. Adleman, *Sci. Am.* **1998**, *279*, 54–61; b) L. M. Adleman, *Science* **1994**, *266*, 1021–1024; c) D. Faulhammer, A. R. Cukras, R. J. Lipton, L. F. Landweber, *Proc. Natl. Acad. Sci. USA* **2000**, *97*, 1385–1389; d) J. Chen, D. H. Wood, *Proc. Natl. Acad. Sci. USA* **2000**, *97*, 1328–1330.
- [21] For selected reviews on supramolecular materials, see: a) P. Kazmaier, N. Chopra, *MRS Bull.* **2000**, *25*, 30–35; b) M. J. Mio, J. S. Moore, *MRS Bull.* **2000**, *25*, 36–41; c) S. I. Stupp, M. U. Pralle, G. N. Tew, L. Li, E. R. Zubarev, *MRS Bull.* **2000**, *25*, 42–48; d) L. Brunsveld, B. J. B. Folmer, E. W. Meijer, *MRS Bull.* **2000**, *25*, 49–53; e) C. J. Hawker, J. L. Hedrick, R. D. Miller, W. Volksen, *MRS Bull.* **2000**, *25*, 54–58; f) T. Kato, *Struct. Bond.* **2000**, *96*, 95–146.